

SuperGrip® Telescopic Aisle Sign Holder – Metal

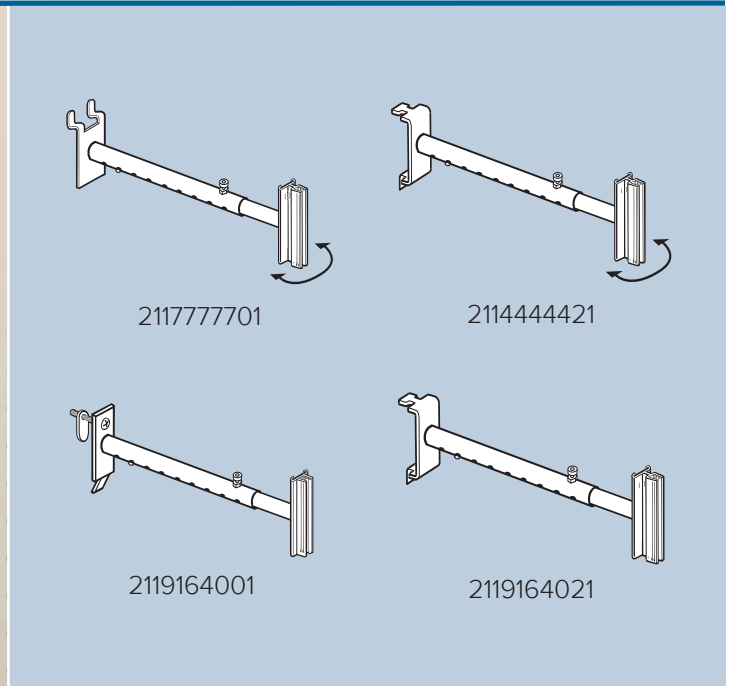

Features and Benefits

- ◆ Securely display aisle signage for maximum visibility
- ◆ Hinge allows sign to flex when bumped SuperGrip® brand holding power
- ◆ Use two holders to support large blade signs
- ◆ Telescoping arm easily adjusts from 13" to 21" L in 1" increments
- ◆ Tool-Free style can be installed without a screwdriver
- ◆ 3" L sign holder; holds material up to .100" thick
- ◆ Powder-coated metal / clear PVC
- ◆ Assembled

Attract attention in the aisle with blade signs

Add excitement in-aisle with the SuperGrip® Telescopic Aisle Sign Holder, Metal. This high-visibility sign holder extends from 13" L to 21" L to penetrate aisles and capture customer attention.

Integrated hinge and SuperGrip® technology offer secure, long-lasting message delivery.

Specifications

Item No.	Ref. No.	Style	Fits	Pack
2114444401	-	w/ hinge	Beige, Gondola Upright	1
2114444421	-	w/ hinge	Beige, Gondola Upright – Tool-Free	1
2117777701	RMA-1321PA	w/ hinge	Beige, Pegboard	1
2154285141	RMA-1321PK	w/ hinge	Black, Pegboard	2
2119164001	RMA-1321UA	w/o hinge	Beige, Gondola Upright	1
2155586919	RMA-1321UK	w/o hinge	Black, Gondola Upright	2
2119164021	-	w/o hinge	Beige, Gondola Upright – Tool-Free	1
2117385301	-	w/o hinge	Beige, Pegboard	1

Additional colors can be made to order (minimum quantities apply.)

20190327

For more information,
call **800.422.2547**
or visit www.siffron.com

siffron[™]
always on